

SE002 Single-ended 300B stereo amplifier.

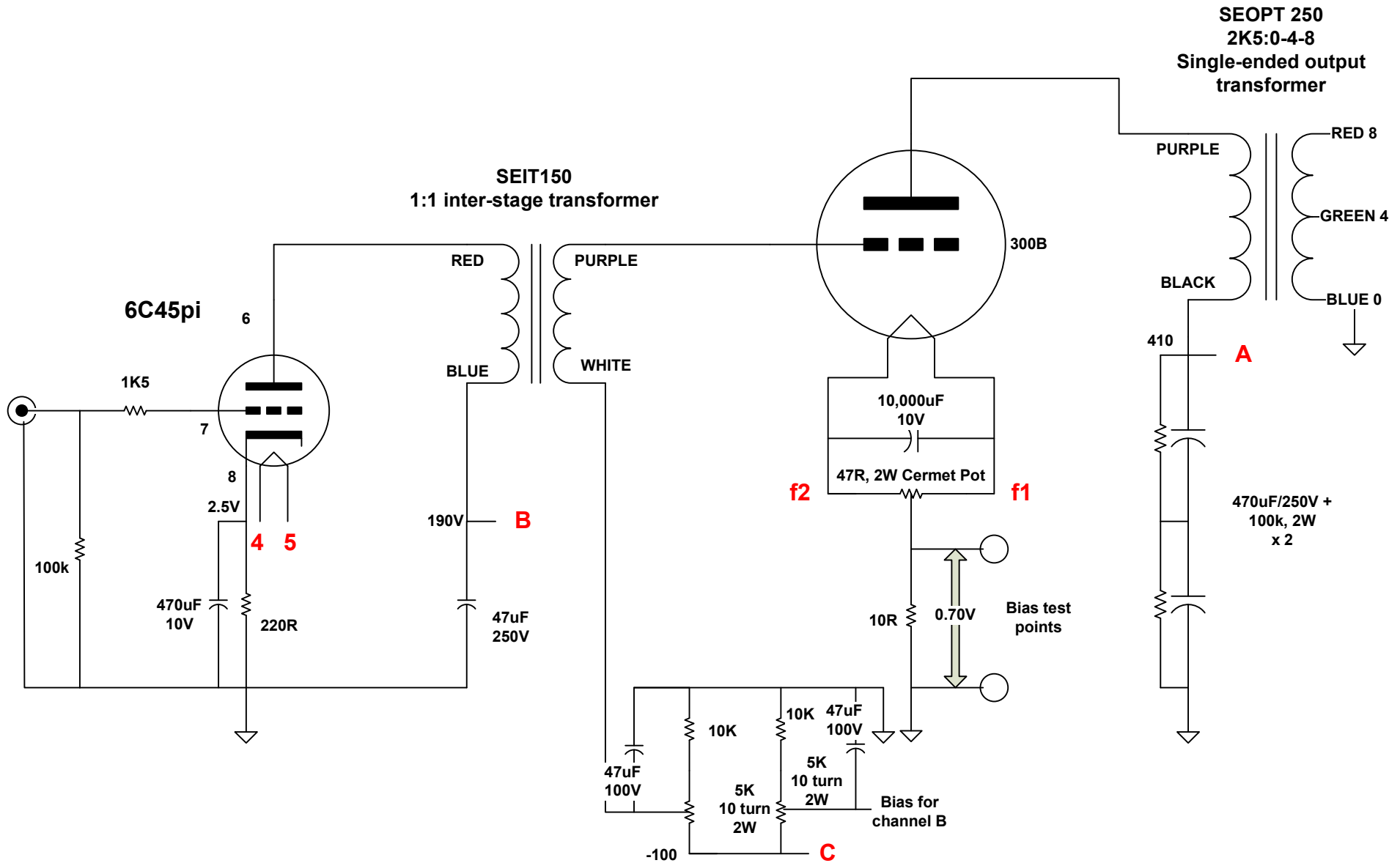

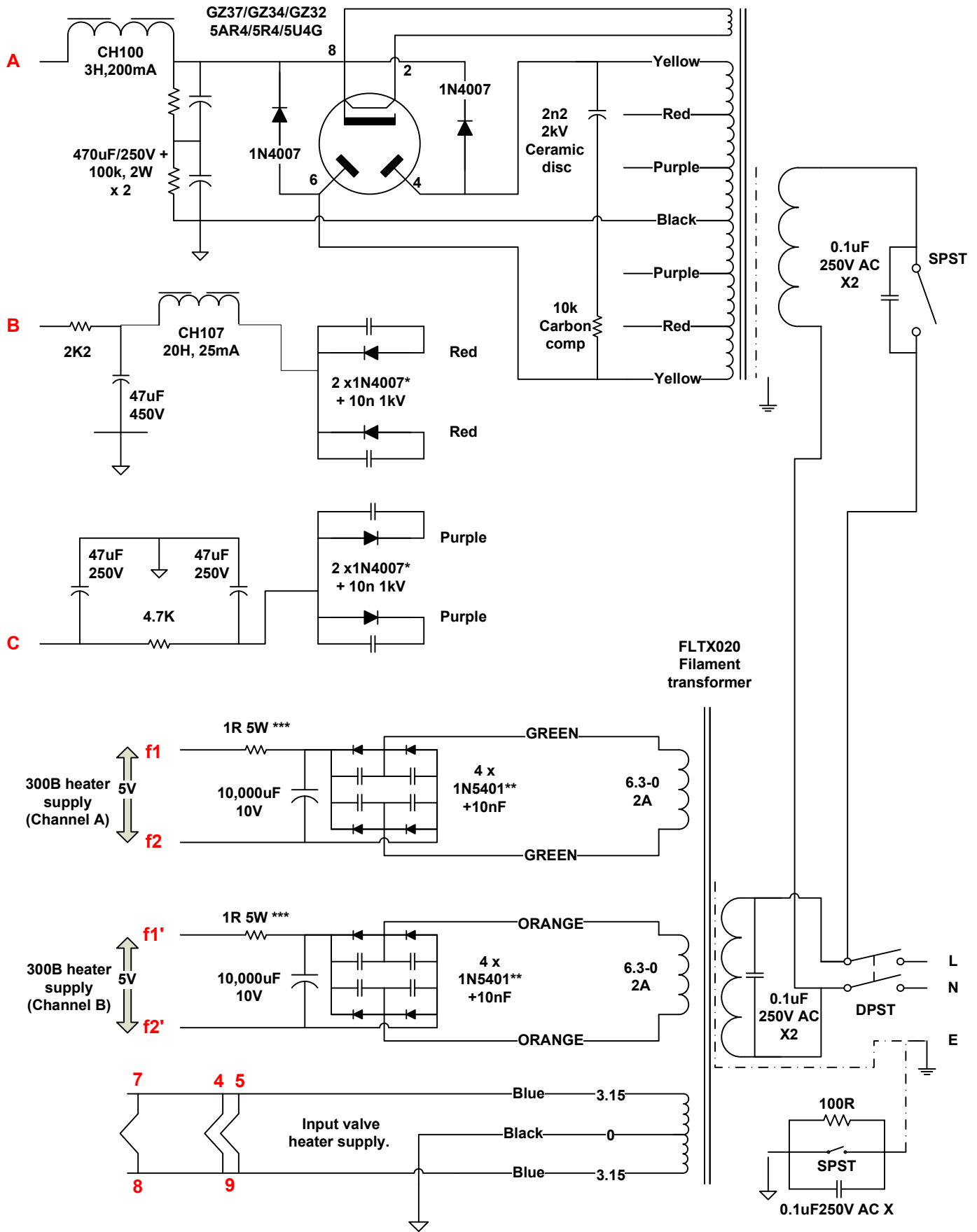

* 1000V soft recovery types can be substituted

** hexfreds or soft recovery diodes can be substituted. Schottky types can also be substituted but an increased resistor value will be required.

*** If an external PSU is used, this resistor value will need to be adjusted to achieve 5V on the 300B filament

TENT labs filament supplies can also be used directly with this filament transformer. If an external supply is used, place the TENT supply in the audio chassis.

SE002 Design Notes

SE002 is a stereo single-ended 300B design using a single 300B/channel and in transformer coupled.

Audio Circuit description:

6C45pi

A Russian 6C45pi combines input and driver duties and drives a pair of 300B's via an inter-stage transformer. One of the so called 'super triodes' the 6C45pi has very high transconductance which makes it an ideal transformer driver and its high gain makes it possible to construct a 2 stage amplifier with reasonable sensitivity. The high transconductance means a grid stopper is essential to prevent oscillation and a quick look at the data sheet shows there are multiple grid and cathode connections. Some designers advocate connecting all the grid connections and cathode connections together whilst others advocate separate grid stoppers and cathode resistors (plus by-pass capacitors) to each connection. The simple scheme shown in the diagram gives excellent sonics but the keen experimenter might want to try out different grid and cathode wiring schemes. Whichever scheme is eventually chosen the lead length of the resistor-valve base connections should be kept as short as possible and direct mounting of the resistor to the valve base pins is advised.

Inter-stage transformer

The inter-stage transformer is a very wide bandwidth design (-3dB 8Hz to >110kHz $r_p=2k5$, $I_a=10-15mA$) and does not ring therefore no Zobel network is required across the secondary. Using the driver transformer allows excursions into Class A2 positive grid which will increase power output on peaks. This amp should provide 9W/channel in Class A but there is quite a lot more available if a blind eye is turned to distortion. Inter-stage transformers are sensitive to hum fields and need to be mounted away from power transformers. If insufficient space is available on the chassis a separate chassis for the power supply components will be required.

Gain and Feedback

This is a low gain design needing approx 1V RMS to generate full power output and should ideally be partnered with an active pre-amplifier. This design has no negative feedback and feedback cannot be applied.

Biasing

The 300B's are operated in fixed bias which is more efficient than cathode bias and also gives tighter bass. A matched pair of 300B's is recommended and individual biasing is shown.

Heaters:

A separate filament transformer is provided and each 300B is DC heated from a resistor-capacitor supply. Each diode in the DC heater circuit is 'snubbed' with a small value capacitor. The output from the filament transformer is specified to allow the use of TENT labs filament supplies, something we endorse highly. The input/driver valve is AC heated.

Power Supply

Driver supply H.T. and bias supply.

Single ended designs work the power supply hard so a separate supply is provided to the input stage to immunise it to the excursions of the output stage. This supply uses choke input filtering for good regulation and noise suppression. The input/ driver H.T. and bias supplies use solid state rectification for reasons of ruggedness, economy and longevity. The diodes are by-passed with snubbing capacitors to kill switching noise. It is remarkable how smooth solid state diodes can sound when these measures are taken. A 10 turn pot is recommended for the bias supply to make accurate adjustment possible.

Output stage H.T.

The output stage supply is unusual as it uses a valve rectifier in parallel with solid state diodes to combine the low impedance and high current capability of solid state with the good sounds of valves. This allows a relatively large input capacitor to be used, something which is not possible with a valve rectifier alone and is good for regulation and therefore bass performance. If the arrangement looks unusual it is, and there are no doubt sceptics that will doubt it's efficacy, but it does sound like a valve rectifier with good bass. It is possible to run without the valve rectifier to save on costs in which case some more snubbing caps will be a good idea.

Turning on.

The separate filament transformer allows the filaments to be warmed before the HT is applied as using a valve rectifier in this configuration does not give a slow start. A few seconds wait is recommended before turning on the HT.