

SE001 Single-ended 300B stereo amplifier.

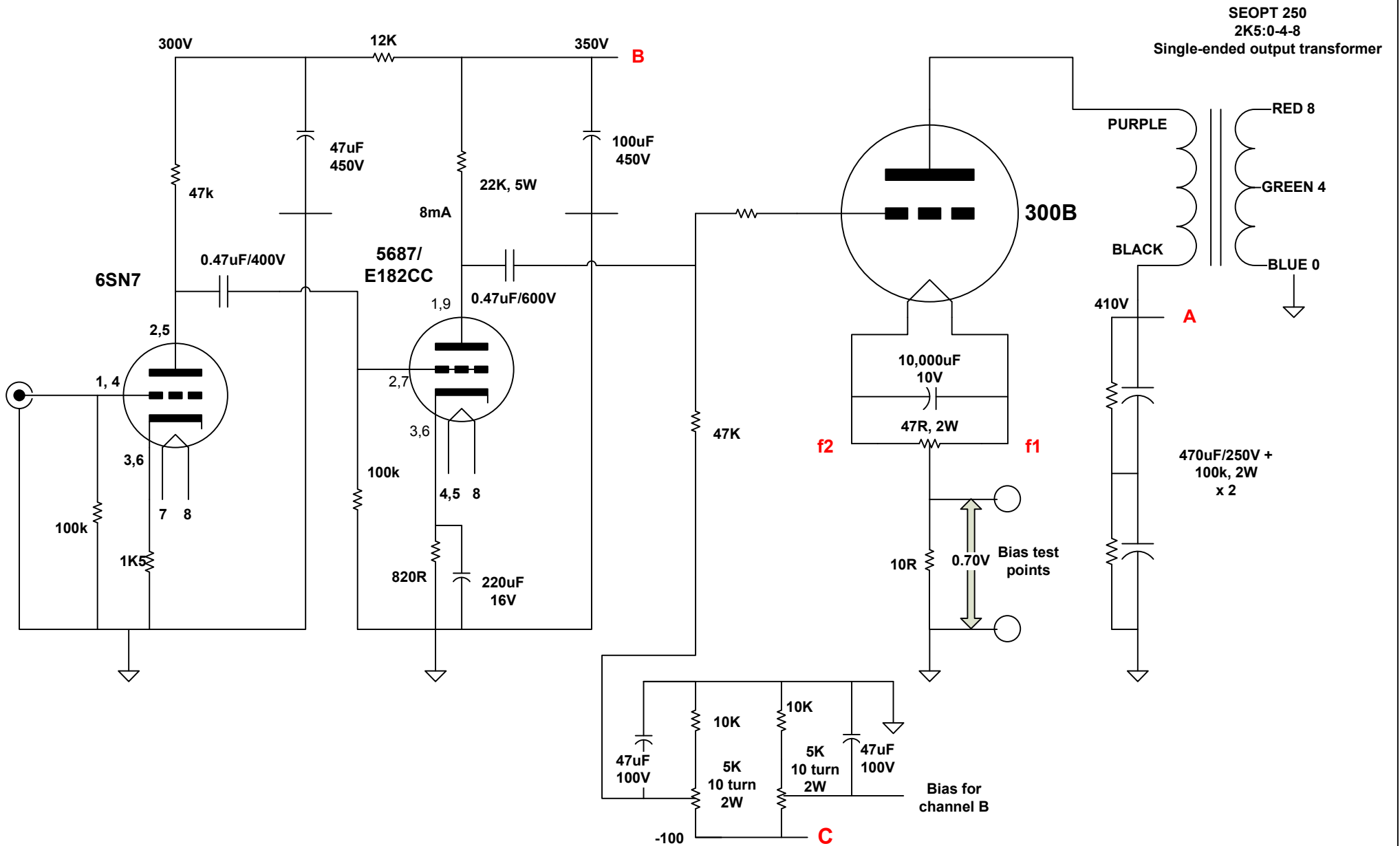

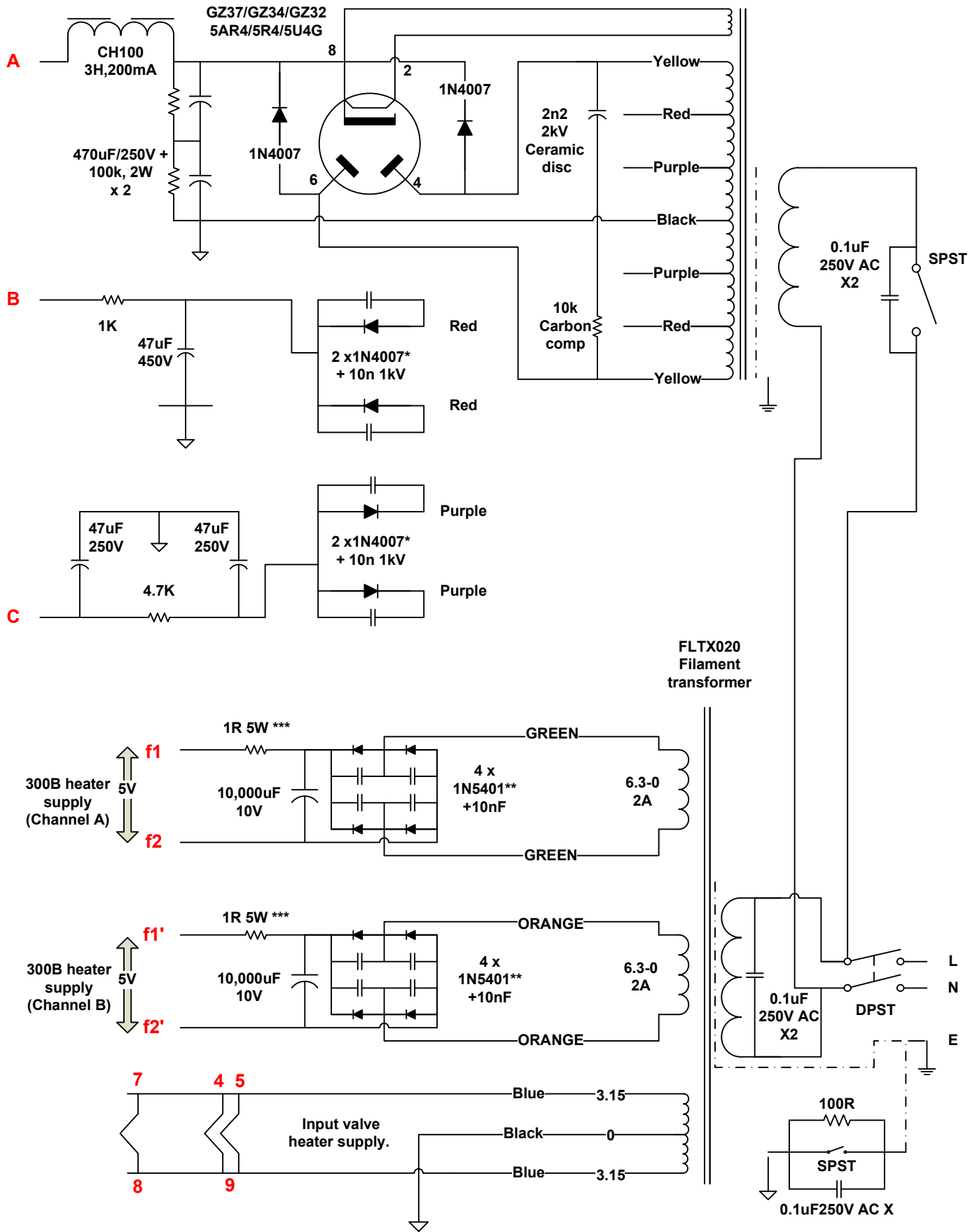

* 1000V soft recovery types can be substituted

** hexfreds or soft recovery diodes can be substituted. Schottky types can also be substituted but an increased resistor value will be required.

*** If an external PSU is used, this resistor value will need to be adjusted to achieve 5V on the 300B filament

TENT labs filament supplies can also be used directly with this filament transformer. If an external supply is used, place the TENT supply in the audio chassis.

SE001 Design Notes

SE001 is a stereo single-ended 300B design using a single 300B/channel and is resistor capacitor coupled.

Audio Circuit description:

One half of the popular 6SN7 triode forms the input stage of the amplifier and is used with an un-by-passed cathode resistor for reasons of both superior sound and gain reduction. This valve is resistor capacitor coupled to one section of a 5687 which works as the driver valve. Many types of 5687 are available, each with a different tone and sonic signature but most of them are rich and full when compared to the directly substitutable E182CC which has a leaner, more energetic sound.

The driver valve is resistor capacitor coupled to the output 300B which is used in fixed bias configuration.

The output transformers are made from high quality M6 laminations and are air gapped to prevent saturation. They have a wide bandwidth -3dB 17Hz to >60kHz and excellent sound.

Resistor Capacitor (RC) coupling.

There is a common assumption that resistor capacitor coupling is worse than inter-stage (IT) coupling. This is not necessarily the case. Both approaches have advantages and disadvantages. IT coupling generally sounds cleaner, faster and more dynamic whereas RC coupling gives a more traditional 'valve amplifier' sound. RC coupling is easier to implement as it takes up less space, there are no inherent hum issues and there is no need for an external power supply unit.

The low impedance 5687 driver allows some excursion into Class A2 positive grid which will increase power output on peaks. This amp should provide 9W/channel in Class A but there is a little more available if a blind eye is turned to distortion.

Gain and Feedback

This is a high gain design needing 400mV < V RMS to generate full power output. This may cause noise and gain problems if it is used with an active pre-amp. If the pre-amp has sufficient output, the 6SN7 stage can be bypassed. This design has no negative feedback but it should be possible to apply it to the cathode of the 6SN7 stage if required.

Biasing

The 300B's are operated in fixed bias which is more efficient than cathode bias and also gives tighter bass. A matched pair of 300B's is recommended and individual biasing is shown.

Heaters:

A separate filament transformer is provided and each 300B is DC heated from a resistor-capacitor supply. Each diode in the DC heater circuit is 'snubbed' with a small value capacitor. The output from the filament transformer is specified to allow the use of TENT labs filament supplies, something we endorse highly.

The input and driver valves are AC heated.

Power Supply

Driver supply H.T. and bias supply.

Single ended designs work the power supply hard so a separate supply is provided to the input stage to immunise it to the excursions of the output stage. The input/ driver H.T. and bias supplies use solid state rectification for reasons of ruggedness, economy and longevity. The diodes are by-passed with snubbing capacitors to kill switching noise. It is remarkable how smooth solid state diodes can sound when these measures are taken. A 10 turn pot is recommended for the bias supply to make accurate adjustment possible.

Output stage H.T.

The output stage supply is unusual as it uses a valve rectifier in parallel with solid state diodes to combine the low impedance and high current capability of solid state with the good sounds of valves. This allows a relatively large input capacitor to be used, something which is not possible with a valve rectifier alone and is good for regulation and therefore bass performance. If the arrangement looks unusual it is, and there are no doubt sceptics that will doubt it's efficacy, but it does sound like a valve rectifier with good bass. It is possible to run without the valve rectifier to save on costs in which case some more snubbing caps will be a good idea.

Turning on.

The separate filament transformer allows the filaments to be warmed before the HT is applied as using a valve rectifier in this configuration does not give a slow start. A few seconds wait is recommended before turning on the HT.